

L:
 CBL-USPD302MBS-0.5m 500mm±10mm
 CBL-USPD302MBS-1m 1000mm±10mm
 CBL-USPD302MBS-2m 2000mm±20mm
 CBL-USPD302MBS-3m 3000mm±20mm

No	MATERIALS LIST:
1.	CABLE:UL2725 (32AWG*1PR+D+AM)x2C+32AWG*1PR+24AWG*1C+AM+B OD:4.2mm PVC JACKET COLOR:BLUE
2.	CONNECTOR:USB 3.0 A/M, 9P, BLUE INSULATOR SOLDER TYPE, NICKEL PLATED SHELL
3.	CONNECTOR:USB 3.0 MicroB/M, 10P, BLACK INSULATOR SOLDER TYPE, NICKEL PLATED SHELL
4.	PVC MOLDED HOUSING, BLUE COLOR
5.	SCREW:#4x33 M2

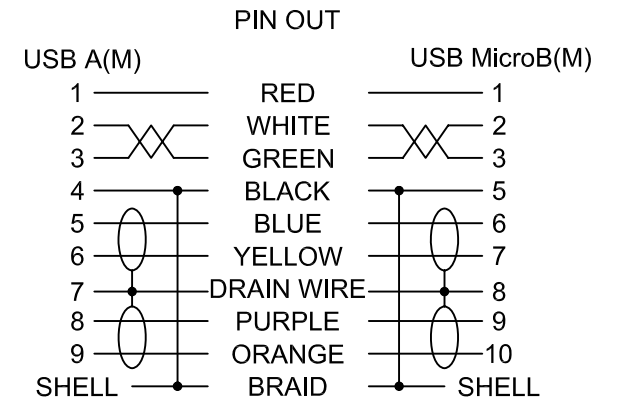

Jargy part no.	Client part no.	Approved	SCALE	UNIT
CBL-USPD302MBS-Xm			1 : 1	mm
Drawing Name		Drawn	Date	REV.
USB 3.0 A to MicroB Cable M/M		<i>Kevin Hsu</i>	2015/08/12	1.0

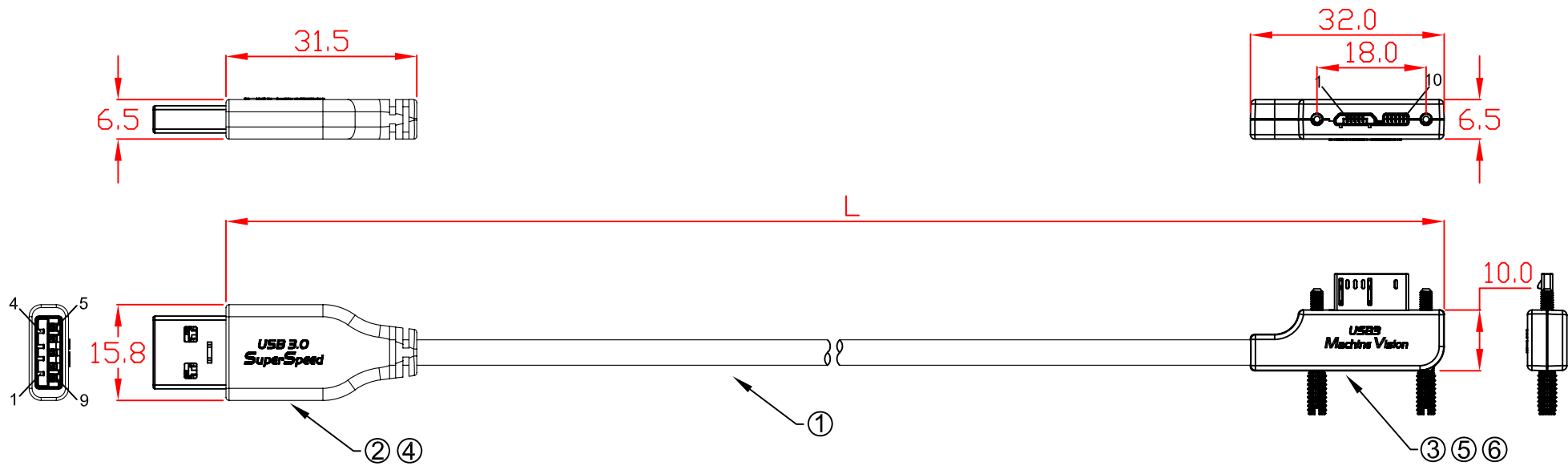

L:

- CBL-USPD302MBS-0.5mLA 500mm±10mm
- CBL-USPD302MBS-1mLA 1000mm±10mm
- CBL-USPD302MBS-2mLA 2000mm±20mm
- CBL-USPD302MBS-3mLA 3000mm±20mm

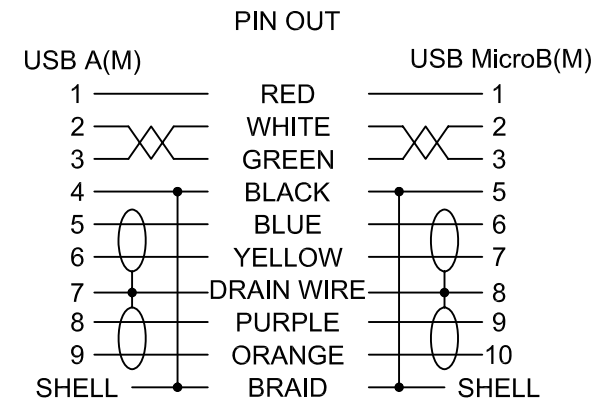

No	MATERIALS LIST:
1.	CABLE:UL2725 (32AWG*1PR+D+AM)x2C+32AWG*1PR+24AWG*1C+AM+B OD:4.2mm PVC JACKET COLOR:BLUE
2.	CONNECTOR:USB 3.0 A/M, 9P, BLUE INSULATOR SOLDER TYPE, NICKEL PLATED SHELL
3.	CONNECTOR:USB 3.0 MicroB/M, 10P, BLACK INSULATOR SOLDER TYPE, NICKEL PLATED SHELL
4.	PVC MOLDED HOUSING, BLUE COLOR
5.	ABS ASSEMBLY HOUSING, BLUE COLOR
6.	SCREW:#3x20.7 M2

Jargy part no.	Client part no.	Approved	SCALE	UNIT
CBL-USPD302MBS-XmLA			1 : 1	mm
Drawing Name		Drawn	Date	REV.
USB 3.0 A to Micro-B Cable M/M		<i>Kevin Hsu</i>	2016/06/03	1.0

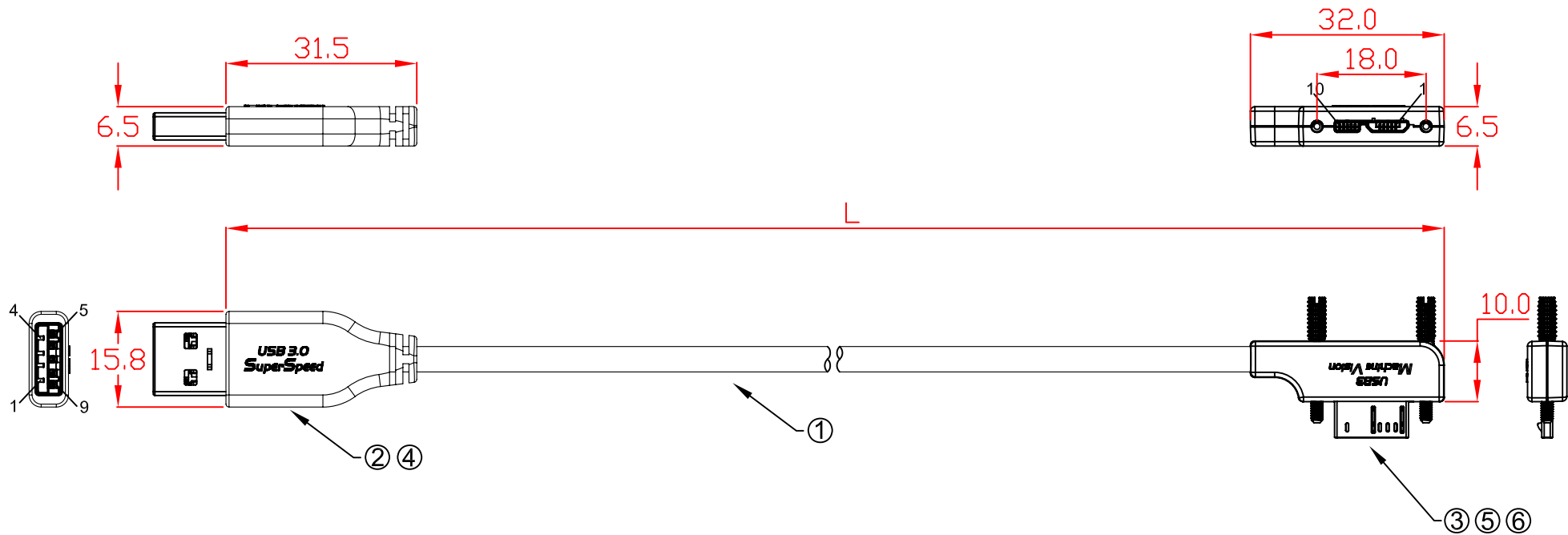

L:

- CBL-USPD302MBS-0.5mRA 500mm±10mm
- CBL-USPD302MBS-1mRA 1000mm±10mm
- CBL-USPD302MBS-2mRA 2000mm±20mm
- CBL-USPD302MBS-3mRA 3000mm±20mm

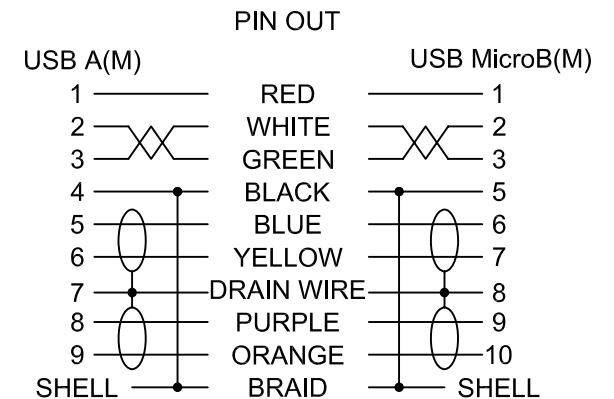

No	MATERIALS LIST:
1.	CABLE:UL2725 (32AWG*1PR+D+AM)x2C+32AWG*1PR+24AWG*1C+AM+B OD:4.2mm PVC JACKET COLOR:BLUE
2.	CONNECTOR:USB 3.0 A/M, 9P, BLUE INSULATOR SOLDER TYPE, NICKEL PLATED SHELL
3.	CONNECTOR:USB 3.0 MicroB/M, 10P, BLACK INSULATOR SOLDER TYPE, NICKEL PLATED SHELL
4.	PVC MOLDED HOUSING, BLUE COLOR
5.	ABS ASSEMBLY HOUSING, BLUE COLOR
6.	SCREW:#3x20.7 M2

Jargy part no.	Client part no.	Approved	SCALE	UNIT
CBL-USPD302MBS-XmRA			1 : 1	mm
Drawing Name		Drawn	Date	REV.
USB 3.0 A to Micro-B Cable M/M		<i>Kevin Hsu</i>	2016/06/03	1.0

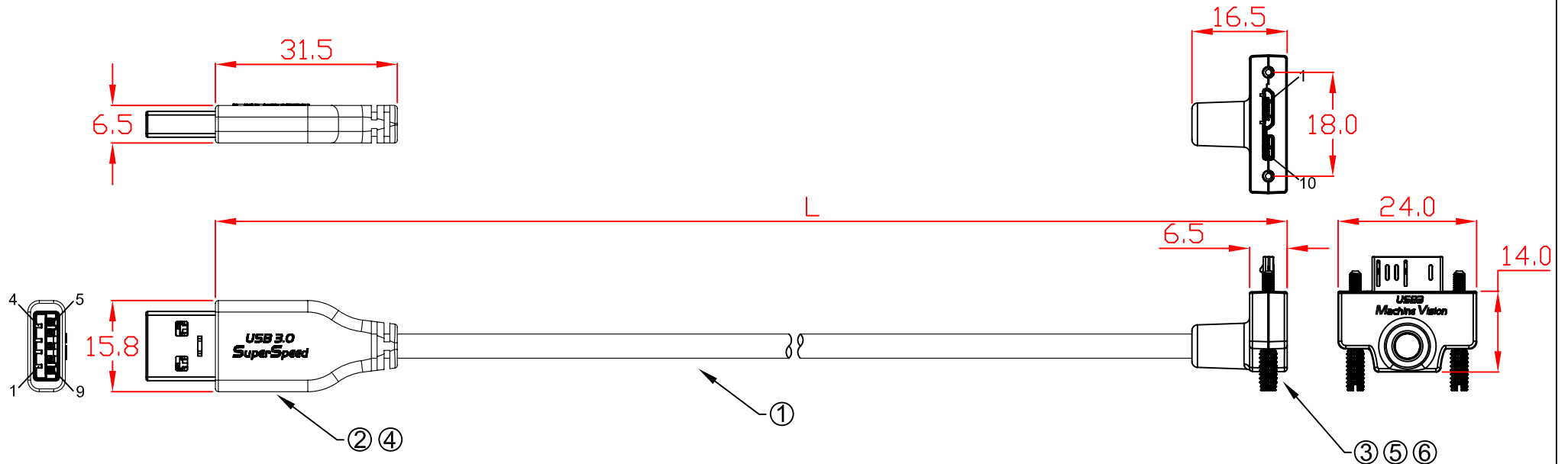

L:

- CBL-USPD302MBS-0.5mUA 500mm±10mm
- CBL-USPD302MBS-1mUA 1000mm±10mm
- CBL-USPD302MBS-2mUA 2000mm±20mm
- CBL-USPD302MBS-3mUA 3000mm±20mm

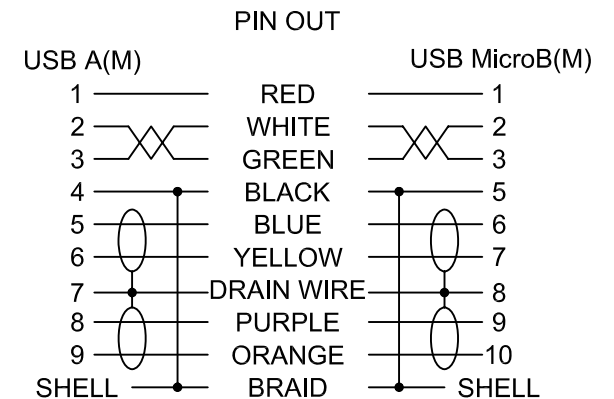

No	MATERIALS LIST:
1.	CABLE:UL2725 (32AWG*1PR+D+AM)x2C+32AWG*1PR+24AWG*1C+AM+B OD:4.2mm PVC JACKET COLOR:BLUE
2.	CONNECTOR:USB 3.0 A/M, 9P, BLUE INSULATOR SOLDER TYPE, NICKEL PLATED SHELL
3.	CONNECTOR:USB 3.0 MicroB/M, 10P, BLACK INSULATOR SOLDER TYPE, NICKEL PLATED SHELL
4.	PVC MOLDED HOUSING, BLUE COLOR
5.	ABS ASSEMBLY HOUSING, BLUE COLOR
6.	SCREW:#3x20.7 M2

Jargy part no.	Client part no.	Approved	SCALE	UNIT
CBL-USPD302MBS-XmUA			1 : 1	mm
Drawing Name		Drawn	Date	REV.
USB 3.0 A to Micro-B Cable M/M		<i>Kevin Hsu</i>	2016/06/03	1.0

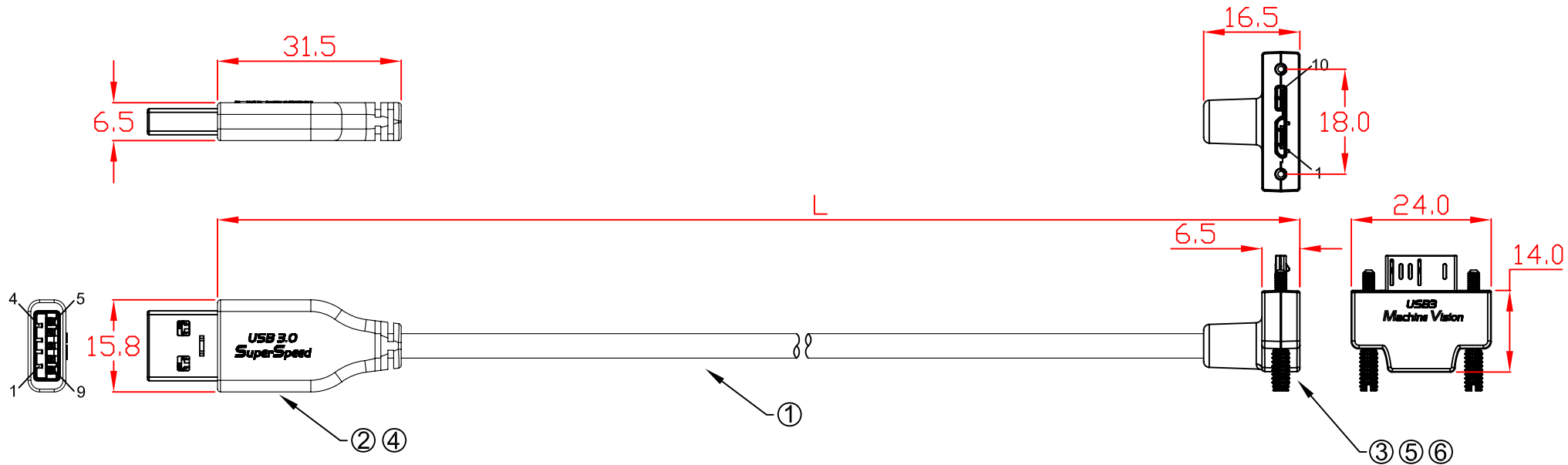

L:

- CBL-USPD302MBS-0.5mDA 500mm±10mm
- CBL-USPD302MBS-1mDA 1000mm±10mm
- CBL-USPD302MBS-2mDA 2000mm±20mm
- CBL-USPD302MBS-3mDA 3000mm±20mm

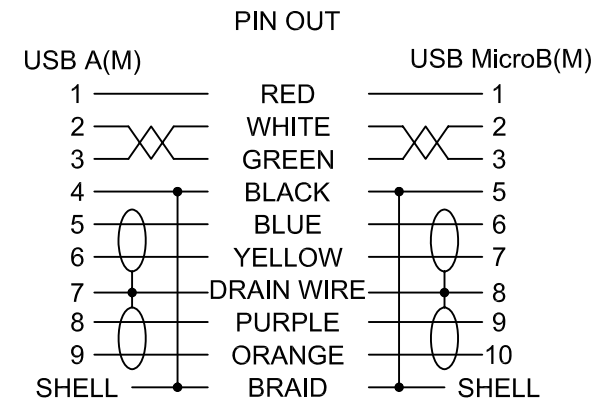

No	MATERIALS LIST:
1.	CABLE:UL2725 (32AWG*1PR+D+AM)x2C+32AWG*1PR+24AWG*1C+AM+B OD:4.2mm PVC JACKET COLOR:BLUE
2.	CONNECTOR:USB 3.0 A/M, 9P, BLUE INSULATOR SOLDER TYPE, NICKEL PLATED SHELL
3.	CONNECTOR:USB 3.0 MicroB/M, 10P, BLACK INSULATOR SOLDER TYPE, NICKEL PLATED SHELL
4.	PVC MOLDED HOUSING, BLUE COLOR
5.	ABS ASSEMBLY HOUSING, BLUE COLOR
6.	SCREW:#3x20.7 M2

Jargy part no.	Client part no.	Approved	SCALE	UNIT
CBL-USPD302MBS-XmDA			1 : 1	mm
Drawing Name		Drawn	Date	REV.
USB 3.0 A to Micro-B Cable M/M		<i>Kevin Hsu</i>	2016/06/03	1.0

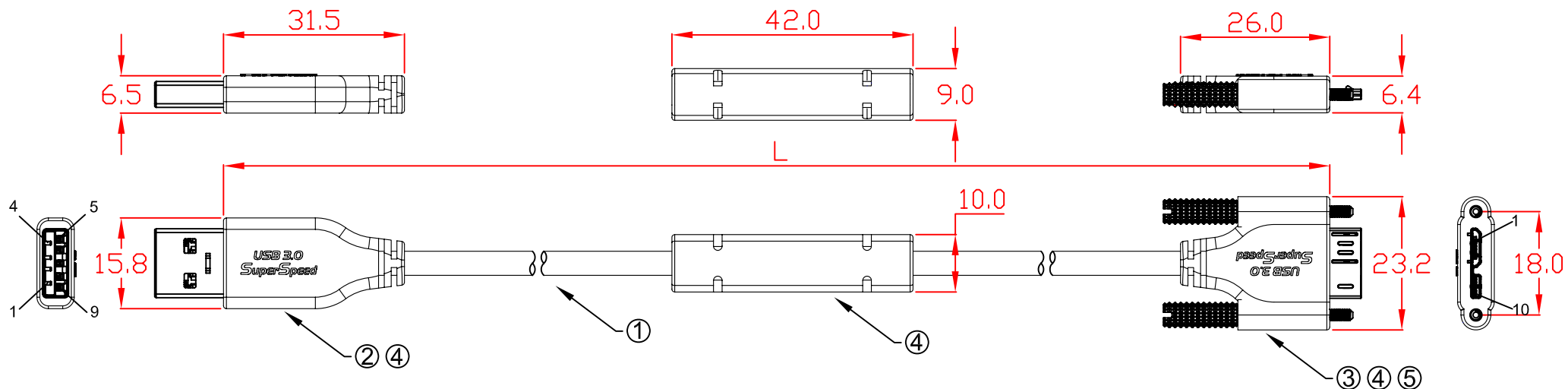

- L:
- CBL-USD302MBS-4m 4000mm±20mm
 - CBL-USD302MBS-5m 5000mm±30mm
 - CBL-USD302MBS-6m 6000mm±30mm
 - CBL-USD302MBS-7m 7000mm±30mm
 - CBL-USD302MBS-8m 8000mm±30mm

No	MATERIALS LIST:
1.	CABLE:UL2725 (32AWG*1PR+D+AM)x2C+32AWG*1PR+24AWG*1C+AM+B OD:4.2mm PVC JACKET COLOR:BLUE
2.	CONNECTOR:USB 3.0 A/M, 9P, BLUE INSULATOR SOLDER TYPE, NICKEL PLATED SHELL
3.	CONNECTOR:USB 3.0 MicroB/M, 10P, BLACK INSULATOR SOLDER TYPE, NICKEL PLATED SHELL
4.	PVC MOLDED HOUSING, BLUE COLOR
5.	SCREW:#4x33 M2

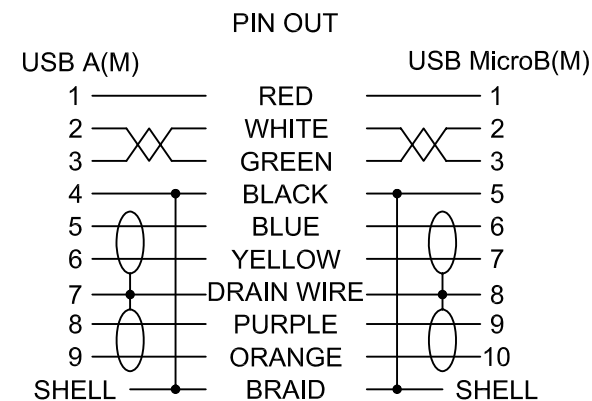

Jargy part no.	Client part no.	Approved	SCALE	UNIT
CBL-USD302MBS-Xm			1 : 1	mm
Drawing Name		Drawn	Date	REV.
USB 3.0 A to MicroB Cable M/M		<i>Kevin Hsu</i>	2015/08/12	1.0

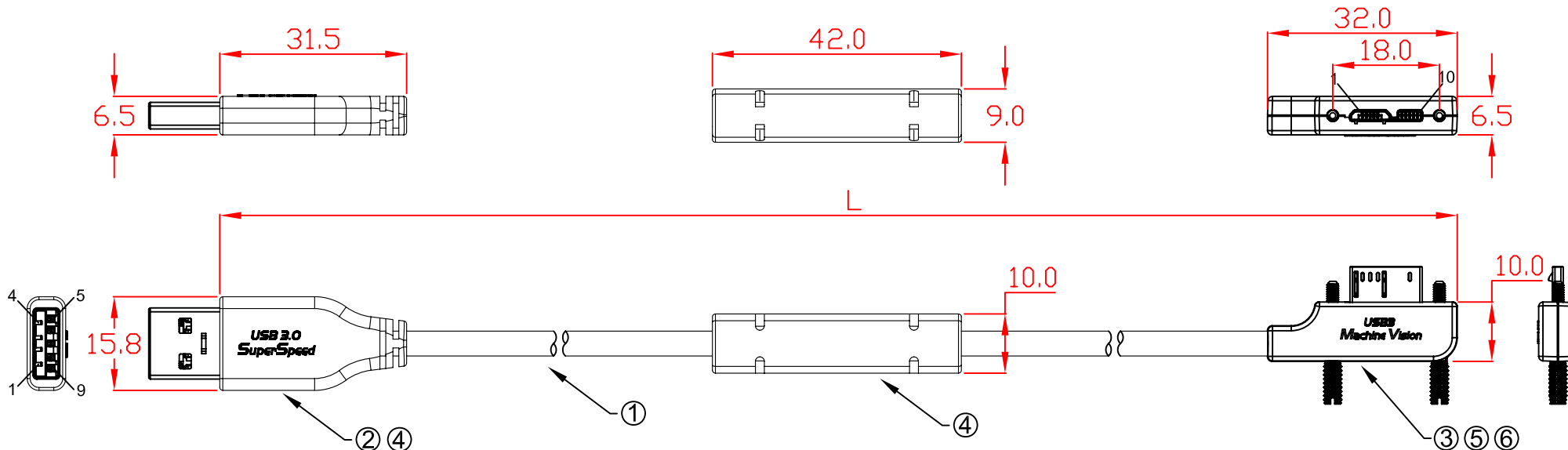

L:

CBL-USD302MBS-4mLA	4000mm±30mm
CBL-USD302MBS-5mLA	5000mm±30mm
CBL-USD302MBS-6mLA	6000mm±30mm
CBL-USD302MBS-7mLA	7000mm±30mm
CBL-USD302MBS-8mLA	8000mm±30mm

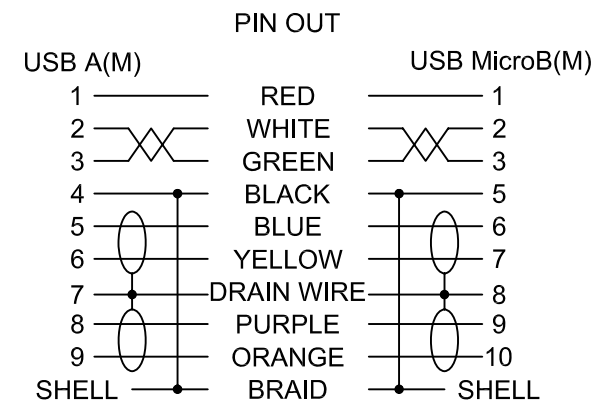

No	MATERIALS LIST:
1.	CABLE:UL2725 (32AWG*1PR+D+AM)x2C+32AWG*1PR+24AWG*1C+AM+B OD:4.2mm PVC JACKET COLOR:BLUE
2.	CONNECTOR:USB 3.0 A/M, 9P, BLUE INSULATOR SOLDER TYPE, NICKEL PLATED SHELL
3.	CONNECTOR:USB 3.0 MicroB/M, 10P, BLACK INSULATOR SOLDER TYPE, NICKEL PLATED SHELL
4.	PVC MOLDED HOUSING, BLUE COLOR
5.	ABS ASSEMBLY HOUSING, BLUE COLOR
6.	SCREW:#3x20.7 M2

Jargy part no.	Client part no.	Approved	SCALE	UNIT
CBL-USD302MBS-XmLA			1 : 1	mm
Drawing Name		Drawn	Date	REV.
USB 3.0 A to Micro-B Cable M/M		<i>Kevin Hsu</i>	2016/06/04	1.0



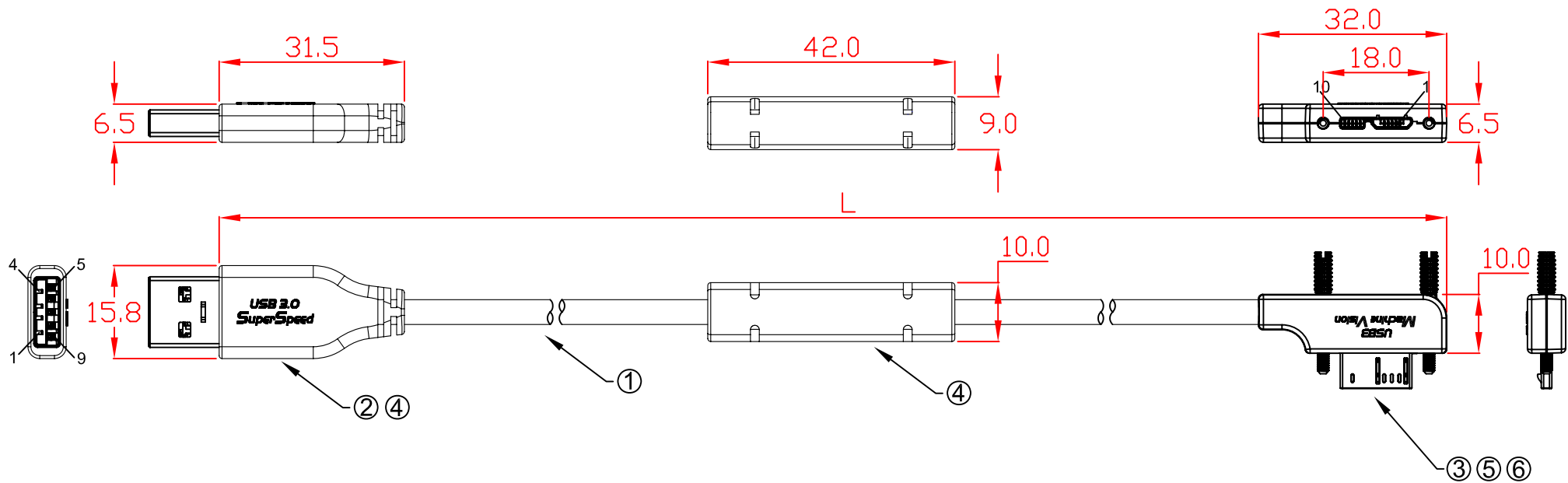

L:

- CBL-USD302MBS-4mRA 4000mm±30mm
- CBL-USD302MBS-5mRA 5000mm±30mm
- CBL-USD302MBS-6mRA 6000mm±30mm
- CBL-USD302MBS-7mRA 7000mm±30mm
- CBL-USD302MBS-8mRA 8000mm±30mm

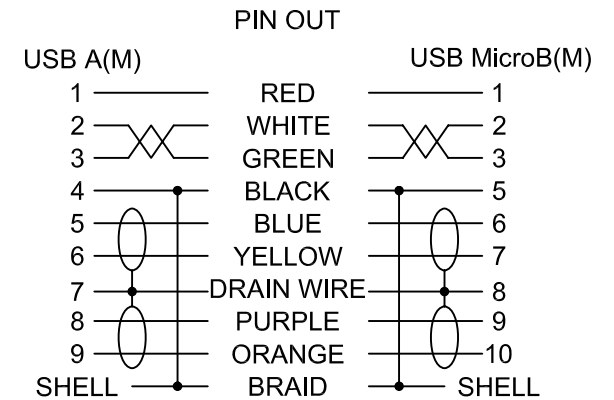

No	MATERIALS LIST:
1.	CABLE:UL2725 (32AWG*1PR+D+AM)x2C+32AWG*1PR+24AWG*1C+AM+B OD:4.2mm PVC JACKET COLOR:BLUE
2.	CONNECTOR:USB 3.0 A/M, 9P, BLUE INSULATOR SOLDER TYPE, NICKEL PLATED SHELL
3.	CONNECTOR:USB 3.0 MicroB/M, 10P, BLACK INSULATOR SOLDER TYPE, NICKEL PLATED SHELL
4.	PVC MOLDED HOUSING, BLUE COLOR
5.	ABS ASSEMBLY HOUSING, BLUE COLOR
6.	SCREW:#3x20.7 M2

Jargy part no.	Client part no.	Approved	SCALE	UNIT
CBL-USD302MBS-XmRA			1 : 1	mm
Drawing Name		Drawn	Date	REV.
USB 3.0 A to Micro-B Cable M/M		<i>Kevin Hsu</i>	2016/06/04	1.0

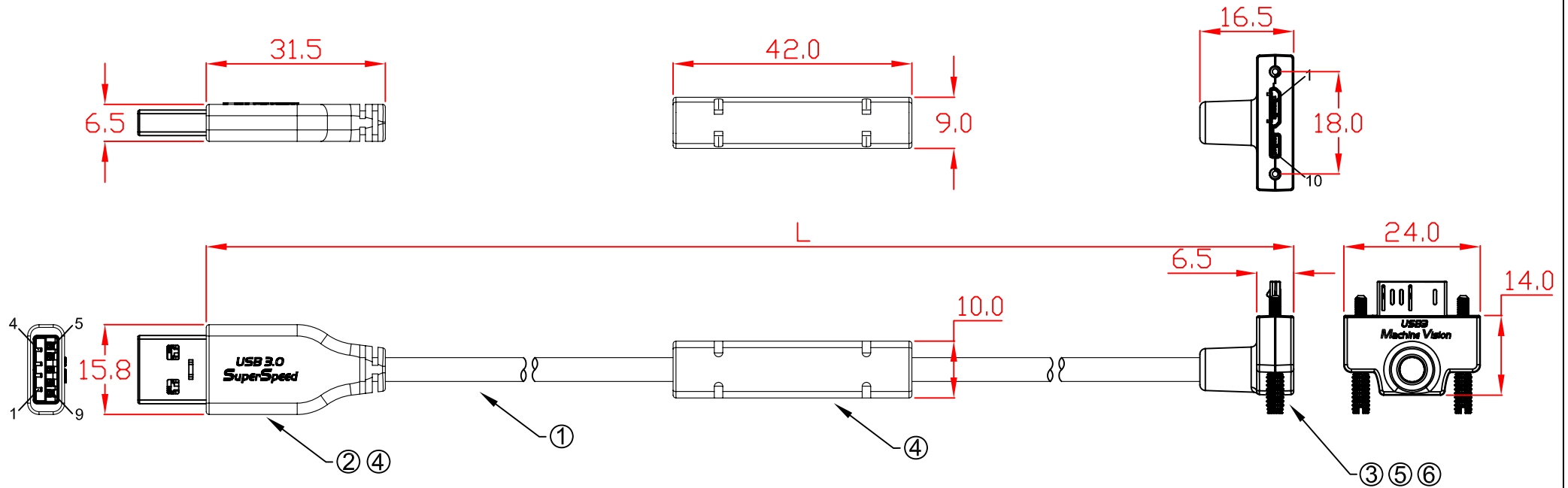

L:

- CBL-USD302MBS-4mUA 4000mm±30mm
- CBL-USD302MBS-5mUA 5000mm±30mm
- CBL-USD302MBS-6mUA 6000mm±30mm
- CBL-USD302MBS-7mUA 7000mm±30mm
- CBL-USD302MBS-8mUA 8000mm±30mm

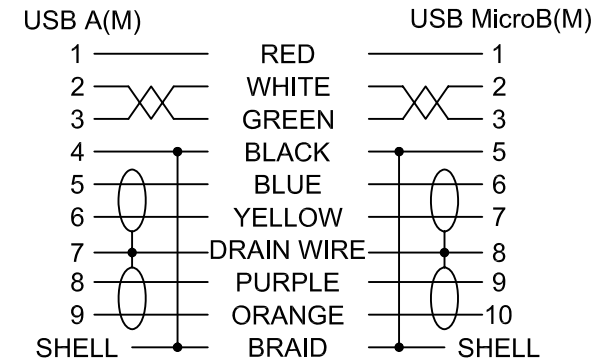

No	MATERIALS LIST:
1.	CABLE:UL2725 (32AWG*1PR+D+AM)x2C+32AWG*1PR+24AWG*1C+AM+B OD:4.2mm PVC JACKET COLOR:BLUE
2.	CONNECTOR:USB 3.0 A/M, 9P, BLUE INSULATOR SOLDER TYPE, NICKEL PLATED SHELL
3.	CONNECTOR:USB 3.0 MicroB/M, 10P, BLACK INSULATOR SOLDER TYPE, NICKEL PLATED SHELL
4.	PVC MOLDED HOUSING, BLUE COLOR
5.	ABS ASSEMBLY HOUSING, BLUE COLOR
6.	SCREW:#3x20.7 M2

Jargy part no.	Client part no.	Approved	SCALE	UNIT
CBL-USD302MBS-XmUA			1 : 1	mm
Drawing Name		Drawn	Date	REV.
USB 3.0 A to Micro-B Cable M/M		<i>Kevin Hsu</i>	2016/06/04	1.0

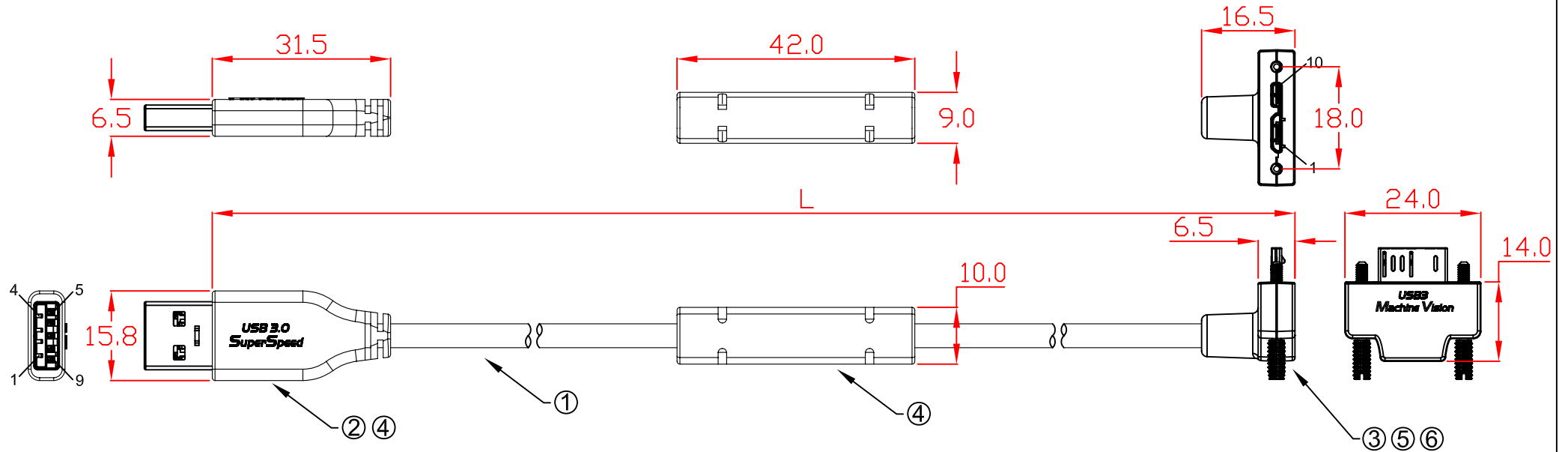

L:

- CBL-USD302MBS-4mDA 4000mm±30mm
- CBL-USD302MBS-5mDA 5000mm±30mm
- CBL-USD302MBS-6mDA 6000mm±30mm
- CBL-USD302MBS-7mDA 7000mm±30mm
- CBL-USD302MBS-8mDA 8000mm±30mm

PIN OUT

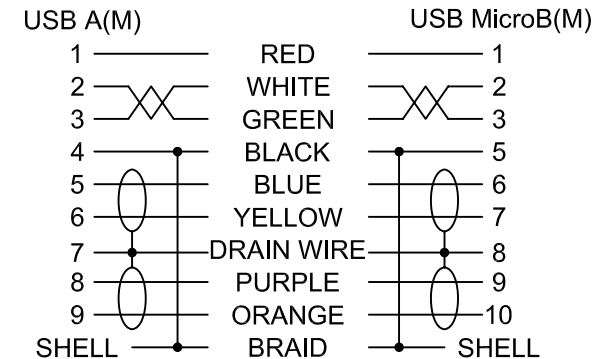

No	MATERIALS LIST:
1.	CABLE:UL2725 (32AWG*1PR+D+AM)x2C+32AWG*1PR+24AWG*1C+AM+B OD:4.2mm PVC JACKET COLOR:BLUE
2.	CONNECTOR:USB 3.0 A/M, 9P, BLUE INSULATOR SOLDER TYPE, NICKEL PLATED SHELL
3.	CONNECTOR:USB 3.0 MicroB/M, 10P, BLACK INSULATOR SOLDER TYPE, NICKEL PLATED SHELL
4.	PVC MOLDED HOUSING, BLUE COLOR
5.	ABS ASSEMBLY HOUSING, BLUE COLOR
6.	SCREW:#3x20.7 M2

Jargy part no.	Client part no.	Approved	SCALE	UNIT
CBL-USD302MBS-XmDA			1 : 1	mm
Drawing Name		Drawn	Date	REV.
USB 3.0 A to Micro-B Cable M/M		<i>Kevin Hsu</i>	2016/06/04	1.0

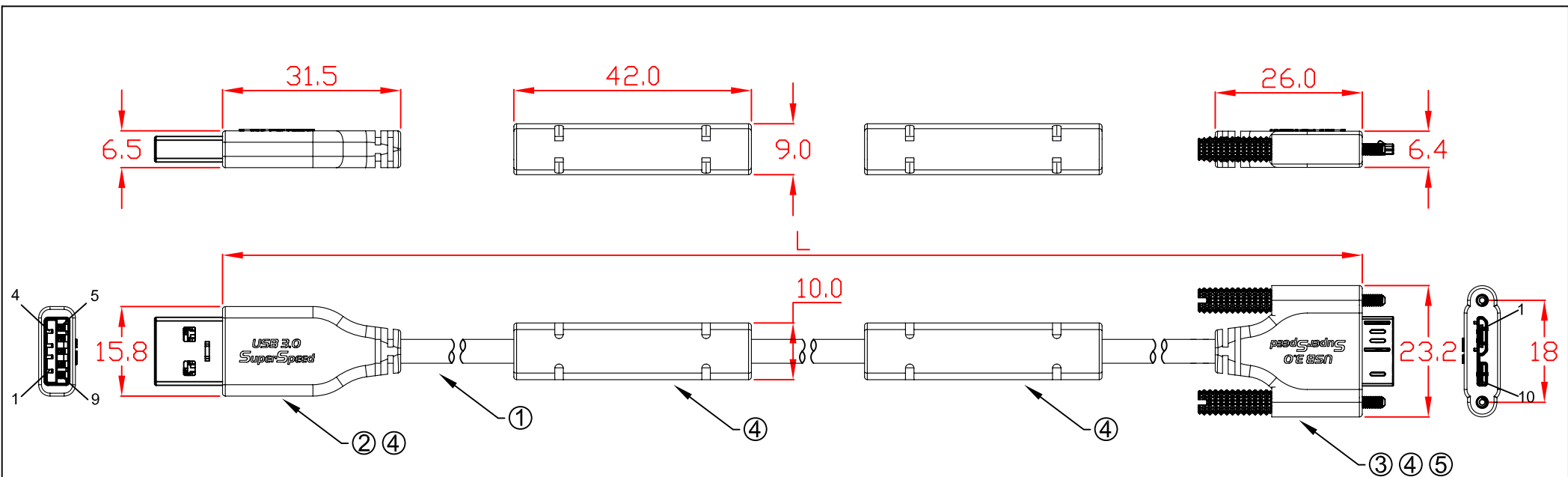

L:

- CBL-USD302MBS-9m 9000mm±30mm
- CBL-USD302MBS-10m 10000mm±30mm
- CBL-USD302MBS-11m 11000mm±30mm
- CBL-USD302MBS-12m 12000mm±30mm

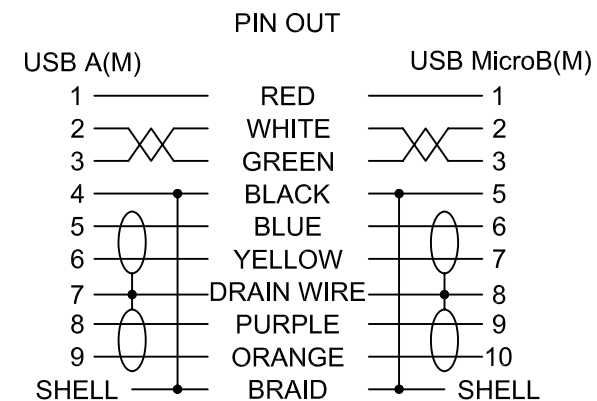

No	MATERIALS LIST:
1.	CABLE:UL2725 (32AWG*1PR+D+AM)x2C+32AWG*1PR+24AWG*1C+AM+B OD:4.2mm PVC JACKET COLOR:BLUE
2.	CONNECTOR:USB 3.0 A/M, 9P, BLUE INSULATOR SOLDER TYPE, NICKEL PLATED SHELL
3.	CONNECTOR:USB 3.0 MicroB/M, 10P, BLACK INSULATOR SOLDER TYPE, NICKEL PLATED SHELL
4.	PVC MOLDED HOUSING, BLUE COLOR
5.	SCREW:#4x33 M2

Jargy part no.	Client part no.	Approved	SCALE	UNIT
CBL-USD302MBS-Xm			1 : 1	mm
Drawing Name		Drawn	Date	REV.
USB 3.0 A to MicroB Cable M/M		<i>Kevin Hsu</i>	2015/08/12	1.0

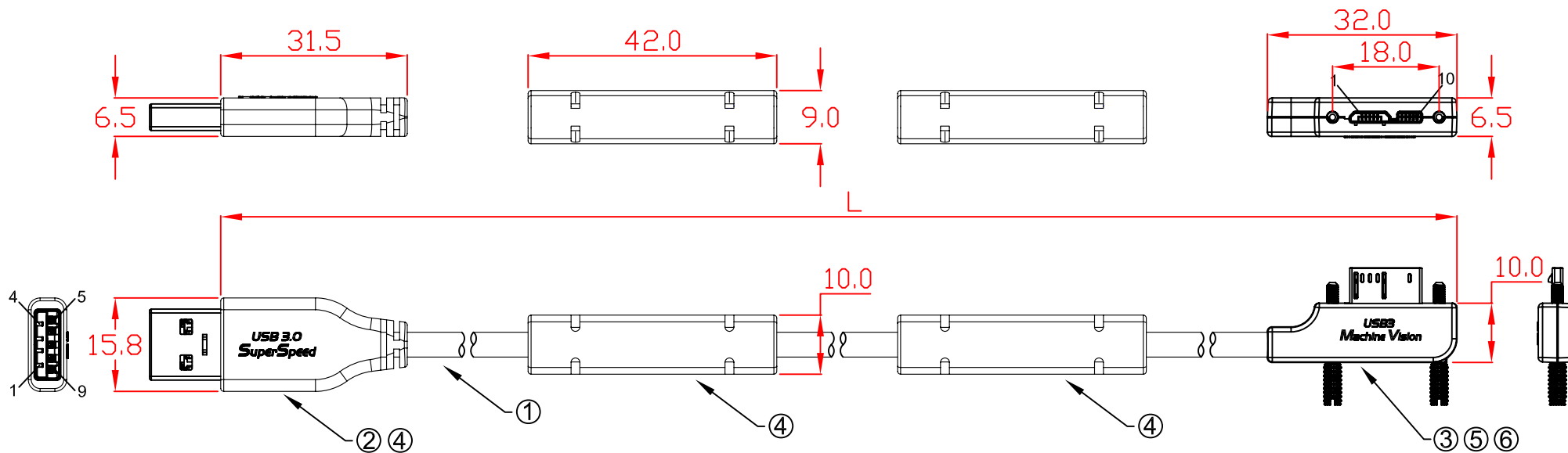

L:

- CBL-USD302MBS-9mLA 9000mm±50mm
- CBL-USD302MBS-10mLA 10000mm±50mm
- CBL-USD302MBS-11mLA 11000mm±50mm
- CBL-USD302MBS-12mLA 12000mm±50mm

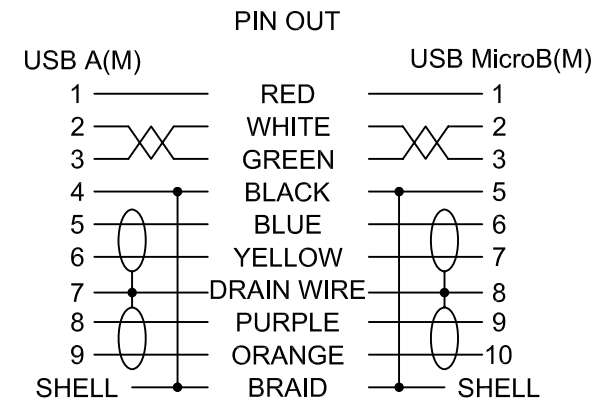

No	MATERIALS LIST:
1.	CABLE:UL2725 (32AWG*1PR+D+AM)x2C+32AWG*1PR+24AWG*1C+AM+B OD:4.2mm PVC JACKET COLOR:BLUE
2.	CONNECTOR:USB 3.0 A/M, 9P, BLUE INSULATOR SOLDER TYPE, NICKEL PLATED SHELL
3.	CONNECTOR:USB 3.0 MicroB/M, 10P, BLACK INSULATOR SOLDER TYPE, NICKEL PLATED SHELL
4.	PVC MOLDED HOUSING, BLUE COLOR
5.	ABS ASSEMBLY HOUSING, BLUE COLOR
6.	SCREW:#3x20.7 M2

Jargy part no.	Client part no.	Approved	SCALE	UNIT
CBL-USD302MBS-XmLA			1 : 1	mm
Drawing Name		Drawn	Date	REV.
USB 3.0 A to Micro-B Cable M/M		<i>Kevin Hsu</i>	2016/06/04	1.0

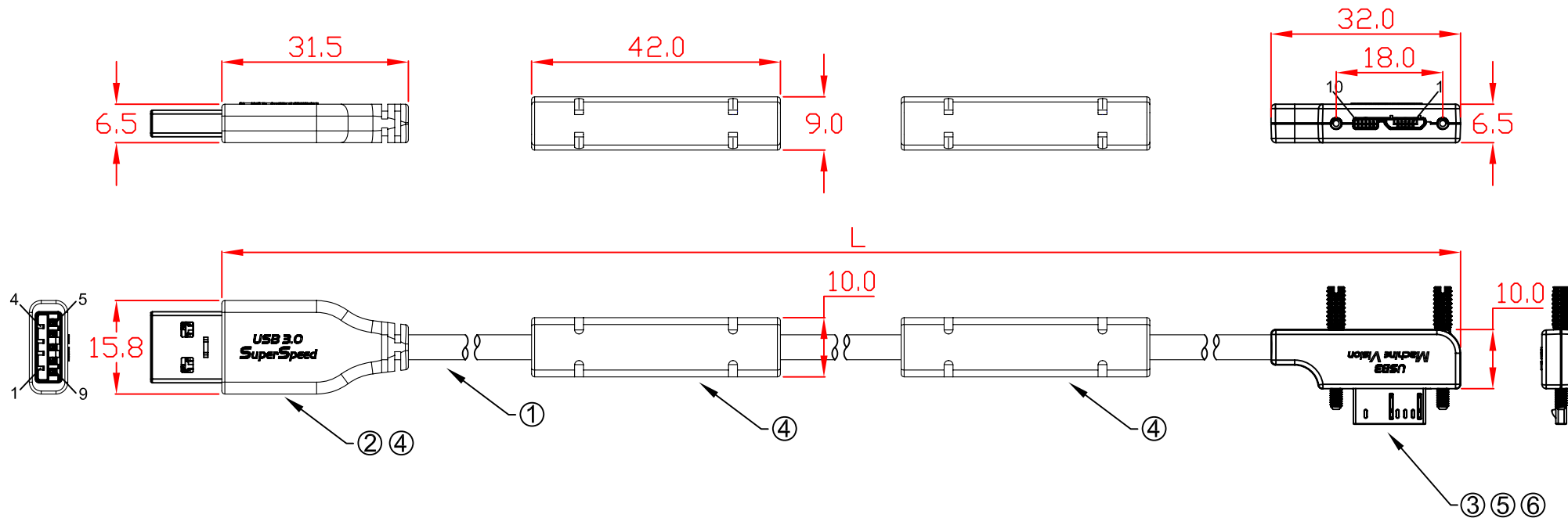

L:

- CBL-USD302MBS-9mRA 9000mm±50mm
- CBL-USD302MBS-10mRA 10000mm±50mm
- CBL-USD302MBS-11mRA 11000mm±50mm
- CBL-USD302MBS-12mRA 12000mm±50mm

PIN OUT

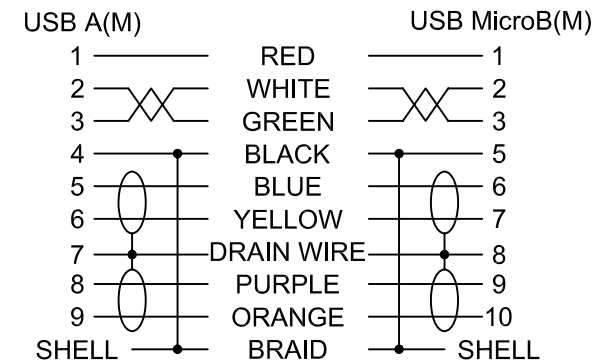

No	MATERIALS LIST:
1.	CABLE:UL2725 (32AWG*1PR+D+AM)x2C+32AWG*1PR+24AWG*1C+AM+B OD:4.2mm PVC JACKET COLOR:BLUE
2.	CONNECTOR:USB 3.0 A/M, 9P, BLUE INSULATOR SOLDER TYPE, NICKEL PLATED SHELL
3.	CONNECTOR:USB 3.0 MicroB/M, 10P, BLACK INSULATOR SOLDER TYPE, NICKEL PLATED SHELL
4.	PVC MOLDED HOUSING, BLUE COLOR
5.	ABS ASSEMBLY HOUSING, BLUE COLOR
6.	SCREW:#3x20.7 M2

Jargy part no.	Client part no.	Approved	SCALE	UNIT
CBL-USD302MBS-XmRA			1 : 1	mm
Drawing Name		Drawn	Date	REV.
USB 3.0 A to Micro-B Cable M/M		<i>Kevin Hsu</i>	2016/06/04	1.0

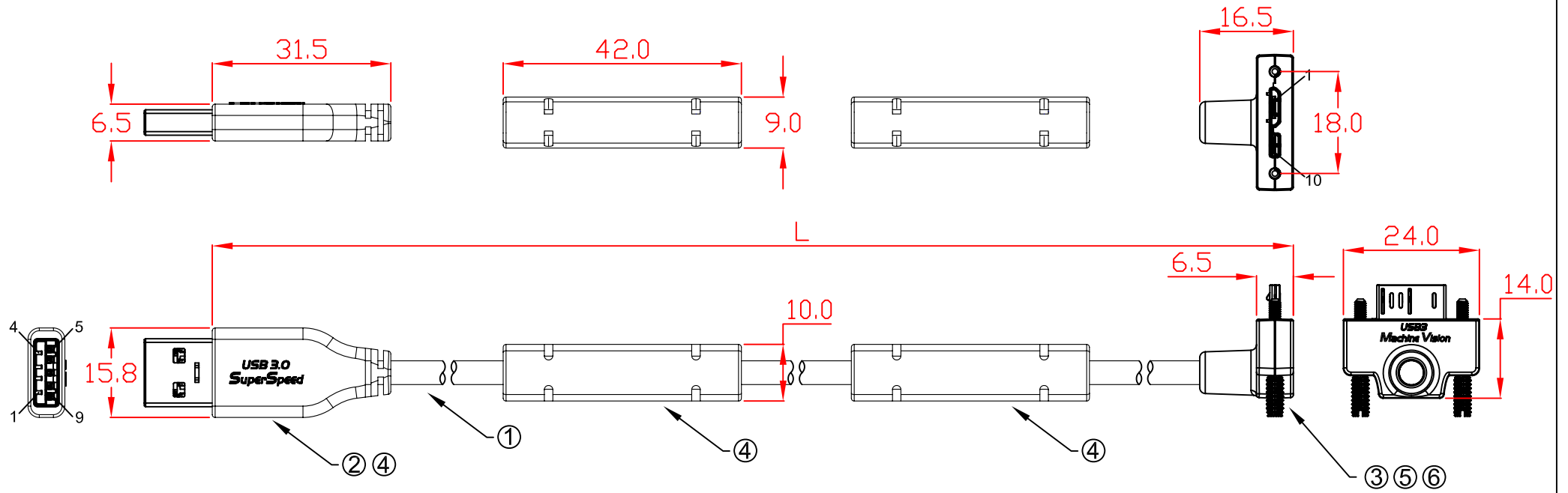

- L:
- | | |
|---------------------|--------------|
| CBL-USD302MBS-9mUA | 9000mm±50mm |
| CBL-USD302MBS-10mUA | 10000mm±50mm |
| CBL-USD302MBS-11mUA | 11000mm±50mm |
| CBL-USD302MBS-12mUA | 12000mm±50mm |

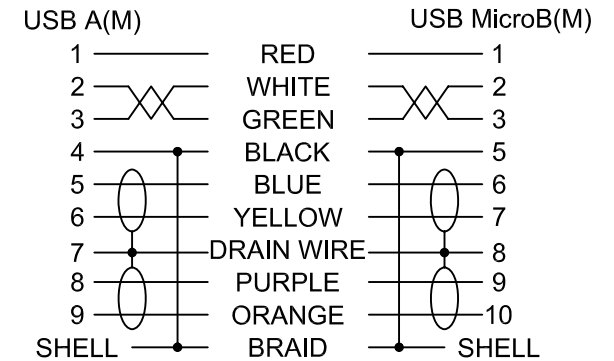

No	MATERIALS LIST:
1.	CABLE:UL2725 (32AWG*1PR+D+AM)x2C+32AWG*1PR+24AWG*1C+AM+B OD:4.2mm PVC JACKET COLOR:BLUE
2.	CONNECTOR:USB 3.0 A/M, 9P, BLUE INSULATOR SOLDER TYPE, NICKEL PLATED SHELL
3.	CONNECTOR:USB 3.0 MicroB/M, 10P, BLACK INSULATOR SOLDER TYPE, NICKEL PLATED SHELL
4.	PVC MOLDED HOUSING, BLUE COLOR
5.	ABS ASSEMBLY HOUSING, BLUE COLOR
6.	SCREW:#3x20.7 M2

Jargy part no.	Client part no.	Approved	SCALE	UNIT
CBL-USD302MBS-XmUA			1 : 1	mm
Drawing Name		Drawn	Date	REV.
USB 3.0 A to Micro-B Cable M/M		<i>Kevin Hsu</i>	2016/06/04	1.0

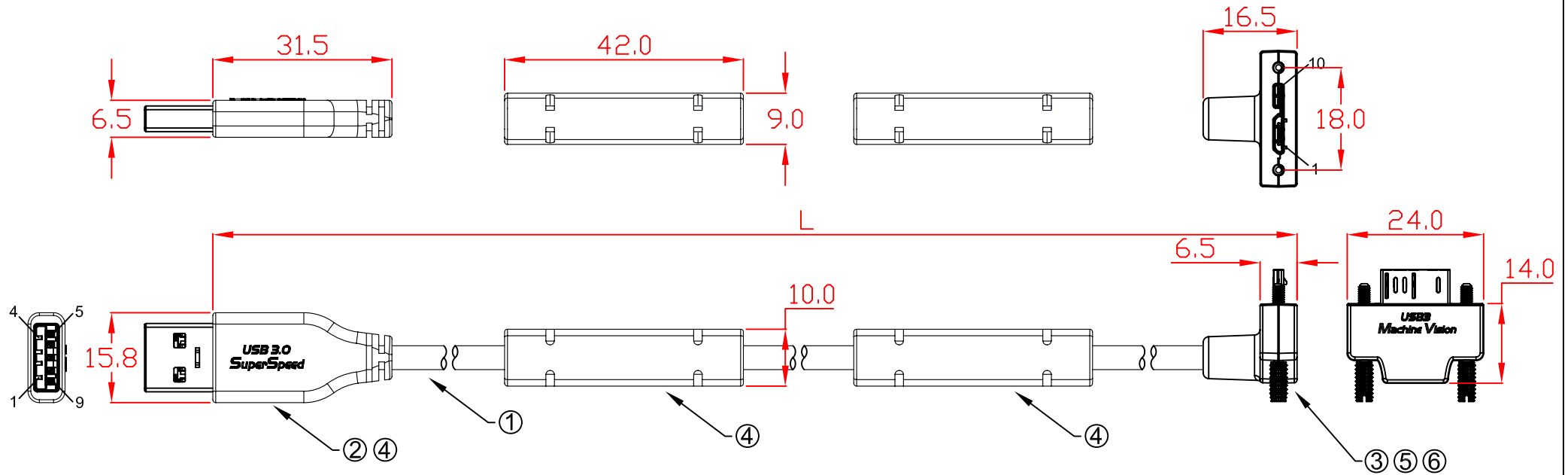

L:

CBL-USD302MBS-9mDA	9000mm±50mm
CBL-USD302MBS-10mDA	10000mm±50mm
CBL-USD302MBS-11mDA	11000mm±50mm
CBL-USD302MBS-12mDA	12000mm±50mm

PIN OUT

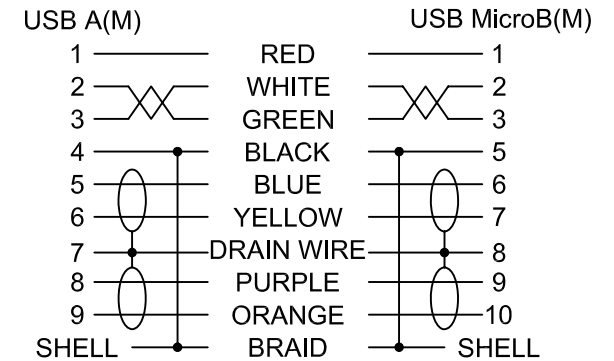

No	MATERIALS LIST:
1.	CABLE:UL2725 (32AWG*1PR+D+AM)x2C+32AWG*1PR+24AWG*1C+AM+B OD:4.2mm PVC JACKET COLOR:BLUE
2.	CONNECTOR:USB 3.0 A/M, 9P, BLUE INSULATOR SOLDER TYPE, NICKEL PLATED SHELL
3.	CONNECTOR:USB 3.0 MicroB/M, 10P, BLACK INSULATOR SOLDER TYPE, NICKEL PLATED SHELL
4.	PVC MOLDED HOUSING, BLUE COLOR
5.	ABS ASSEMBLY HOUSING, BLUE COLOR
6.	SCREW:#3x20.7 M2

Jargy part no.	Client part no.	Approved	SCALE	UNIT
CBL-USD302MBS-XmDA			1 : 1	mm
Drawing Name		Drawn	Date	REV.
USB 3.0 A to Micro-B Cable M/M		<i>Kevin Hsu</i>	2016/06/04	1.0

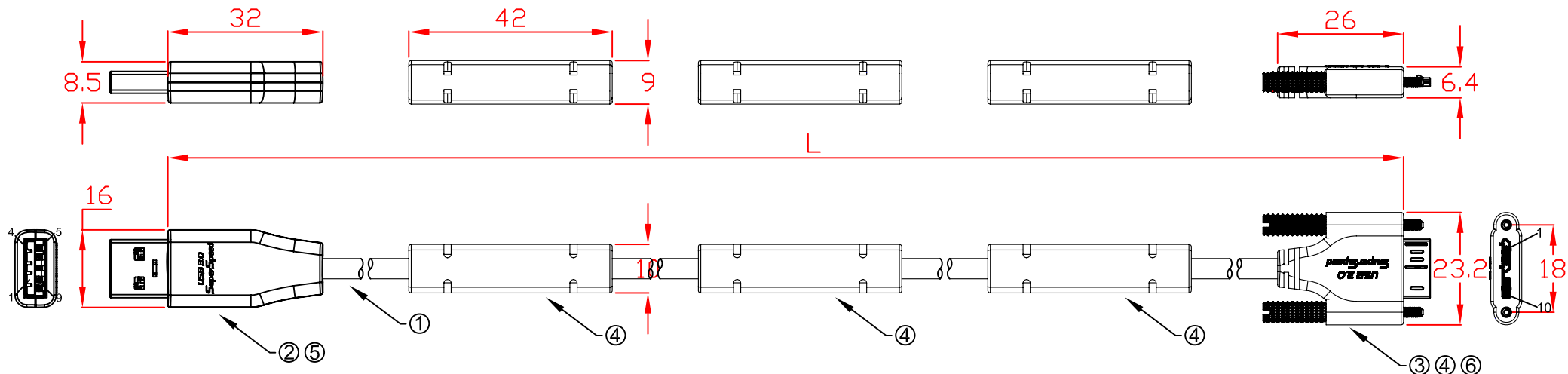

L:

- CBL-USD302MBS-13m 13000mm±50mm
- CBL-USD302MBS-14m 14000mm±50mm
- CBL-USD302MBS-15m 15000mm±50mm
- CBL-USD302MBS-16m 16000mm±50mm

PIN OUT

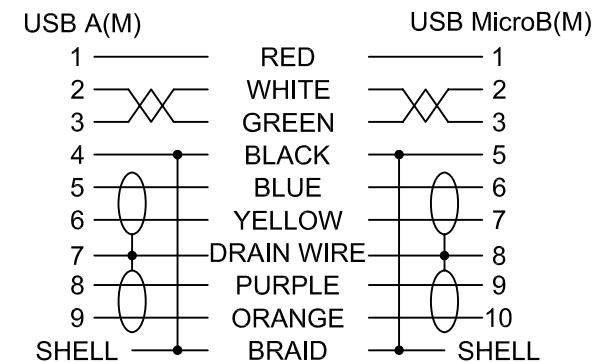

No	MATERIALS LIST:
1.	CABLE:UL2725 (32AWG*1PR+D+AM)x2C+32AWG*1PR+24AWG*1C+AM+B OD:4.2mm PVC JACKET COLOR:BLUE
2.	CONNECTOR:USB 3.0 A/M, 9P, BLUE INSULATOR SOLDER TYPE, NICKEL PLATED SHELL
3.	CONNECTOR:USB 3.0 MicroB/M, 10P, BLACK INSULATOR SOLDER TYPE, NICKEL PLATED SHELL
4.	PVC MOLDED HOUSING, BLUE COLOR
5.	ABS ASSEMBLY HOUSING, BLUE COLOR
6.	SCREW:#4x33 M2

Jargy part no.	Client part no.	Approved	SCALE	UNIT
CBL-USD302MBS-Xm			1 : 2	mm
Drawing Name		Drawn	Date	REV.
USB 3.0 A to Micro-B Cable M/M		<i>Kevin Hsu</i>	2016/06/14	1.0

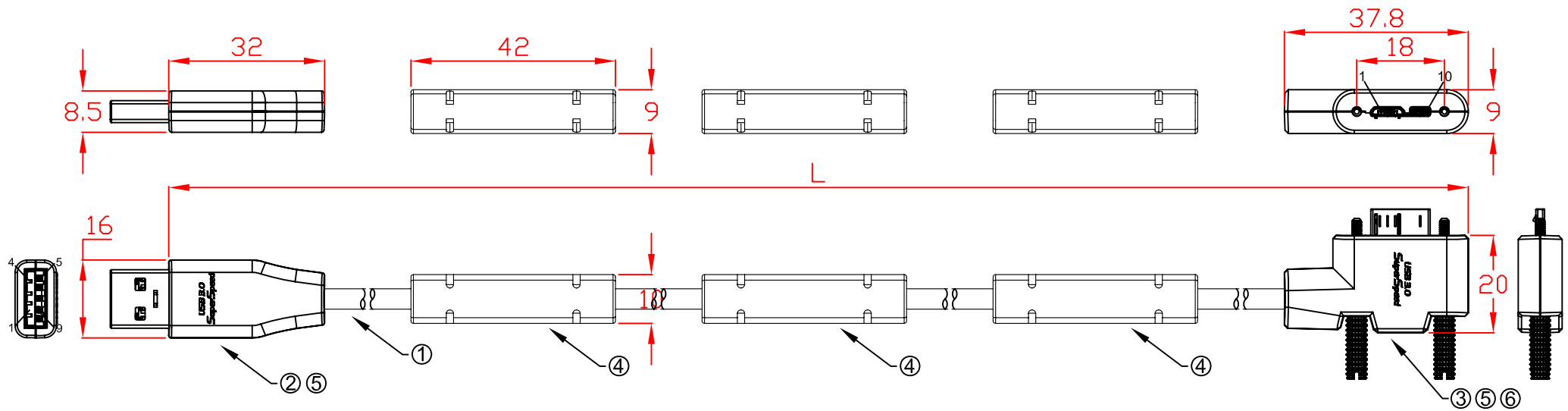

L:

- CBL-USD302MBS-13mLA 13000mm±50mm
- CBL-USD302MBS-14mLA 14000mm±50mm
- CBL-USD302MBS-15mLA 15000mm±50mm
- CBL-USD302MBS-16mLA 16000mm±50mm

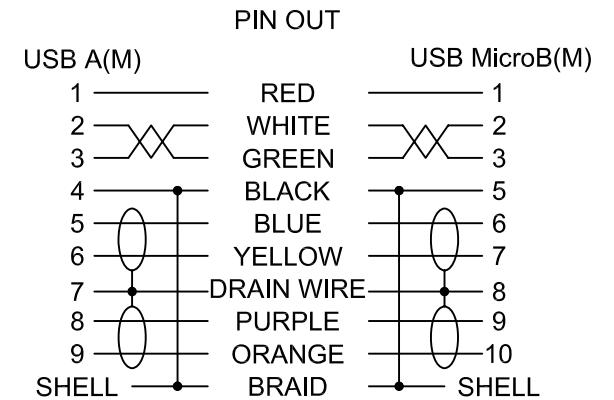

No	MATERIALS LIST:
1.	CABLE:UL2725 (32AWG*1PR+D+AM)x2C+32AWG*1PR+24AWG*1C+AM+B OD:4.2mm PVC JACKET COLOR:BLUE
2.	CONNECTOR:USB 3.0 A/M, 9P, BLUE INSULATOR SOLDER TYPE, NICKEL PLATED SHELL
3.	CONNECTOR:USB 3.0 MicroB/M, 10P, BLACK INSULATOR SOLDER TYPE, NICKEL PLATED SHELL
4.	PVC MOLDED HOUSING, BLUE COLOR
5.	ABS ASSEMBLY HOUSING, BLUE COLOR
6.	SCREW:#4x33 M2

Jargy part no.	Client part no.	Approved	SCALE	UNIT
CBL-USD302MBS-XmLA			1 : 2	mm
Drawing Name		Drawn	Date	REV.
USB 3.0 A to Micro-B Cable M/M		<i>Kevin Hsu</i>	2016/06/06	1.0

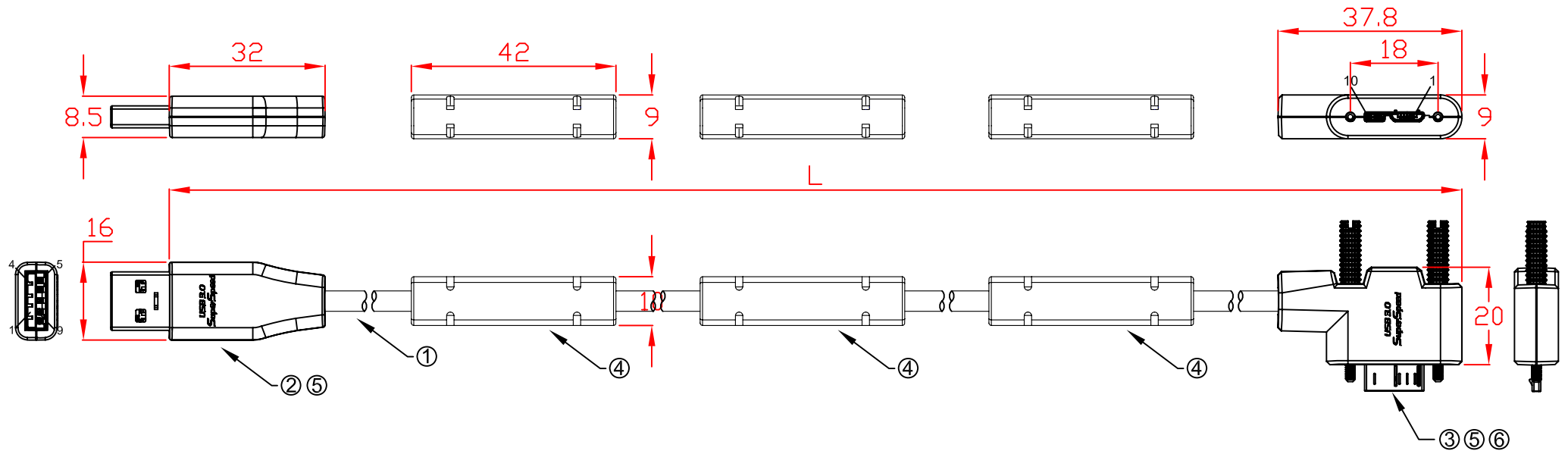

L:

CBL-USD302MBS-13mRA	13000mm±50mm
CBL-USD302MBS-14mRA	14000mm±50mm
CBL-USD302MBS-15mRA	15000mm±50mm
CBL-USD302MBS-16mRA	16000mm±50mm

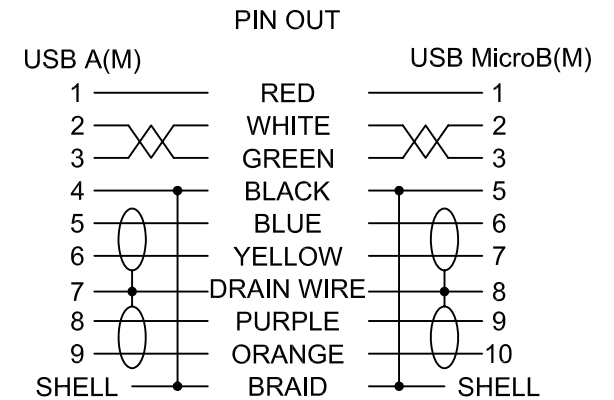

No	MATERIALS LIST:
1.	CABLE:UL2725 (32AWG*1PR+D+AM)x2C+32AWG*1PR+24AWG*1C+AM+B OD:4.2mm PVC JACKET COLOR:BLUE
2.	CONNECTOR:USB 3.0 A/M, 9P, BLUE INSULATOR SOLDER TYPE, NICKEL PLATED SHELL
3.	CONNECTOR:USB 3.0 MicroB/M, 10P, BLACK INSULATOR SOLDER TYPE, NICKEL PLATED SHELL
4.	PVC MOLDED HOUSING, BLUE COLOR
5.	ABS ASSEMBLY HOUSING, BLUE COLOR
6.	SCREW:#4x33 M2

Jargy part no.	Client part no.	Approved	SCALE	UNIT
CBL-USD302MBS-XmRA			1 : 2	mm
Drawing Name		Drawn	Date	REV.
USB 3.0 A to Micro-B Cable M/M		<i>Kevin Hsu</i>	2016/06/06	1.0

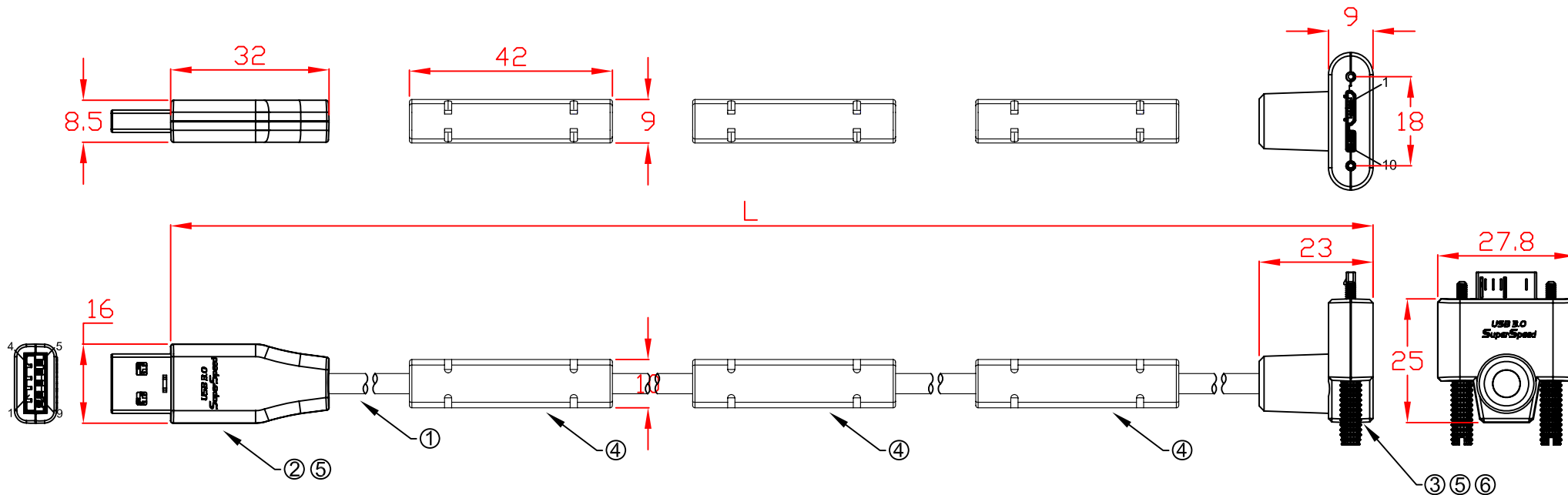

L:

- CBL-USD302MBS-13mUA 13000mm±50mm
- CBL-USD302MBS-14mUA 14000mm±50mm
- CBL-USD302MBS-15mUA 15000mm±50mm
- CBL-USD302MBS-16mUA 16000mm±50mm

USB A(M)

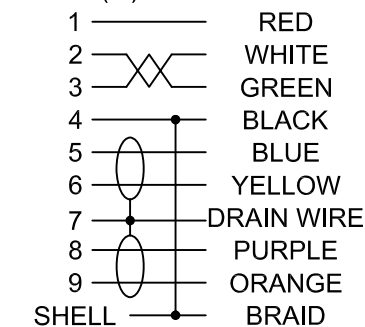

USB MicroB(M)

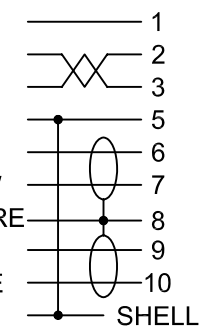

No	MATERIALS LIST:
1.	CABLE:UL2725 (32AWG*1PR+D+AM)x2C+32AWG*1PR+24AWG*1C+AM+B OD:4.2mm PVC JACKET COLOR:BLUE
2.	CONNECTOR:USB 3.0 A/M, 9P, BLUE INSULATOR SOLDER TYPE, NICKEL PLATED SHELL
3.	CONNECTOR:USB 3.0 MicroB/M, 10P, BLACK INSULATOR SOLDER TYPE, NICKEL PLATED SHELL
4.	PVC MOLDED HOUSING, BLUE COLOR
5.	ABS ASSEMBLY HOUSING, BLUE COLOR
6.	SCREW:#4x33 M2

Jargy part no.	Client part no.	Approved	SCALE	UNIT
CBL-USD302MBS-XmUA			1 : 2	mm
Drawing Name		Drawn	Date	REV.
USB 3.0 A to Micro-B Cable M/M		<i>Kevin Hsu</i>	2016/06/06	1.0



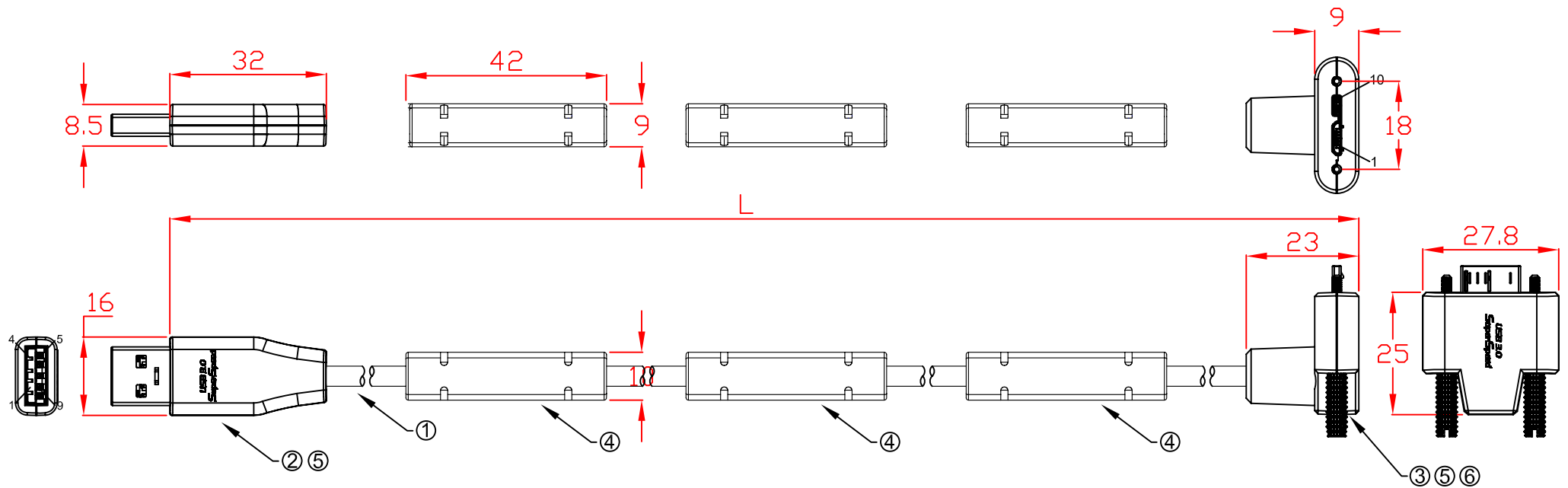

- L:
- CBL-USD302MBS-13mDA 13000mm±50mm
 - CBL-USD302MBS-14mDA 14000mm±50mm
 - CBL-USD302MBS-15mDA 15000mm±50mm
 - CBL-USD302MBS-16mDA 16000mm±50mm

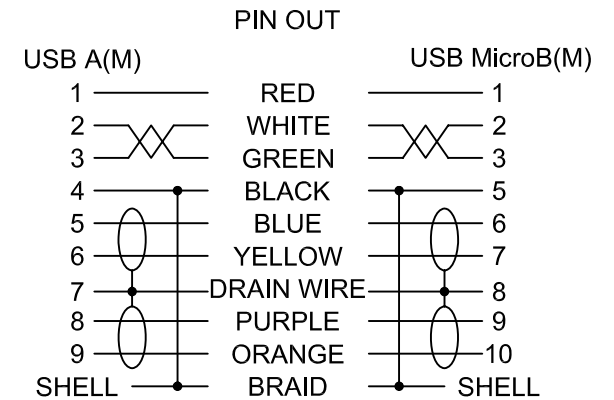

No	MATERIALS LIST:
1.	CABLE:UL2725 (32AWG*1PR+D+AM)x2C+32AWG*1PR+24AWG*1C+AM+B OD:4.2mm PVC JACKET COLOR:BLUE
2.	CONNECTOR:USB 3.0 A/M, 9P, BLUE INSULATOR SOLDER TYPE, NICKEL PLATED SHELL
3.	CONNECTOR:USB 3.0 MicroB/M, 10P, BLACK INSULATOR SOLDER TYPE, NICKEL PLATED SHELL
4.	PVC MOLDED HOUSING, BLUE COLOR
5.	ABS ASSEMBLY HOUSING, BLUE COLOR
6.	SCREW:#4x33 M2

Jargy part no.	Client part no.	Approved	SCALE	UNIT
CBL-USD302MBS-XmDA			1 : 2	mm
Drawing Name		Drawn	Date	REV.
USB 3.0 A to Micro-B Cable M/M		<i>Kevin Hsu</i>	2016/06/06	1.0

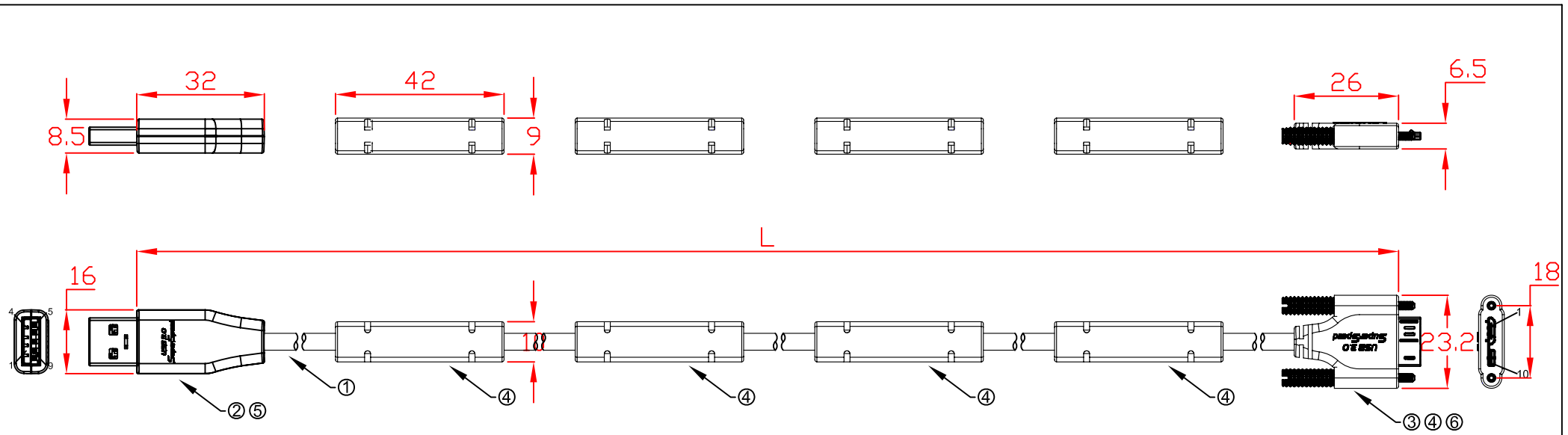

L:

- CBL-USD302MBS-17m 17000mm±50mm
- CBL-USD302MBS-18m 18000mm±50mm
- CBL-USD302MBS-19m 19000mm±50mm
- CBL-USD302MBS-20m 20000mm±50mm

PIN OUT

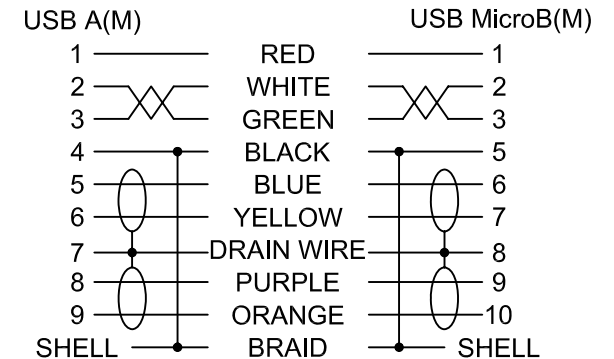

No	MATERIALS LIST:
1.	CABLE:UL2725 (32AWG*1PR+D+AM)x2C+32AWG*1PR+24AWG*1C+AM+B OD:4.2mm PVC JACKET COLOR:BLUE
2.	CONNECTOR:USB 3.0 A/M, 9P, BLUE INSULATOR SOLDER TYPE, NICKEL PLATED SHELL
3.	CONNECTOR:USB 3.0 MicroB/M, 10P, BLACK INSULATOR SOLDER TYPE, NICKEL PLATED SHELL
4.	PVC MOLDED HOUSING, BLUE COLOR
5.	ABS ASSEMBLY HOUSING, BLUE COLOR
6.	SCREW:#4x33 M2

Jargy part no.	Client part no.	Approved	SCALE	UNIT
CBL-USD302MBS-Xm			1 : 2	mm
Drawing Name		Drawn	Date	REV.
USB 3.0 A to Micro-B Cable M/M		<i>Kevin Hsu</i>	2016/06/14	1.0

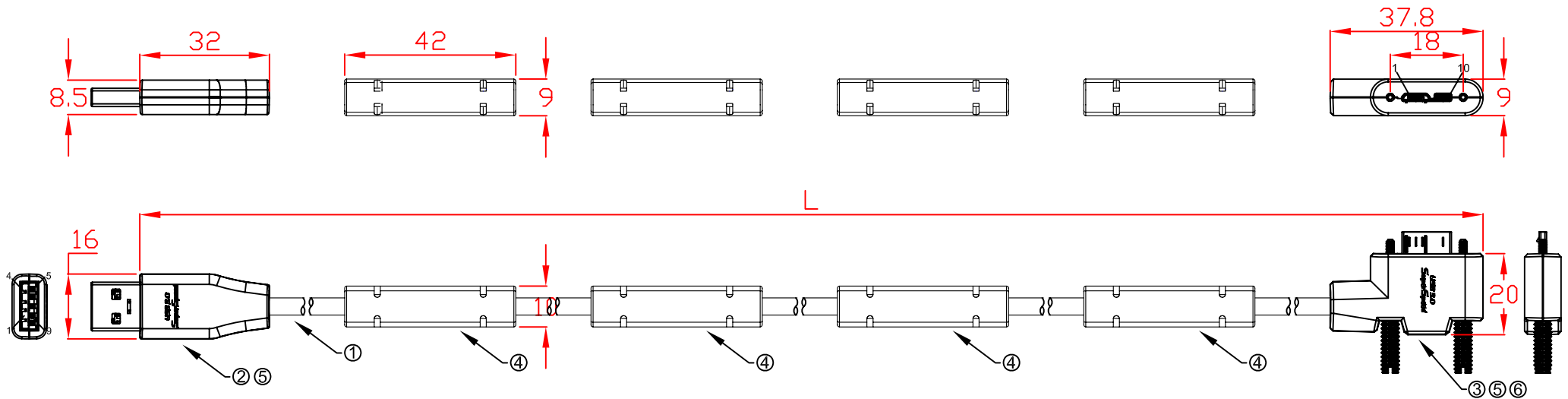

L:

- CBL-USD302MBS-17mLA 17000mm±50mm
- CBL-USD302MBS-18mLA 18000mm±50mm
- CBL-USD302MBS-19mLA 19000mm±50mm
- CBL-USD302MBS-20mLA 20000mm±50mm

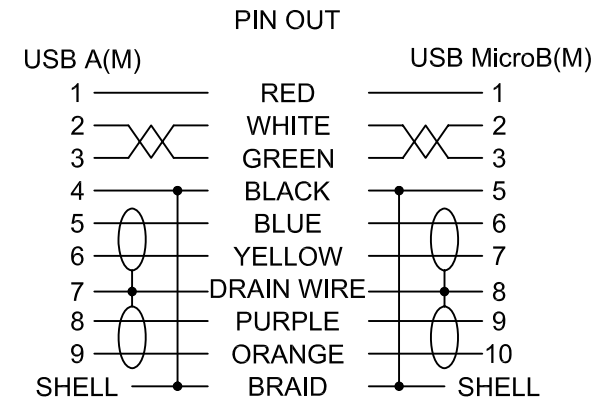

No	MATERIALS LIST:
1.	CABLE:UL2725 (32AWG*1PR+D+AM)x2C+32AWG*1PR+24AWG*1C+AM+B OD:4.2mm PVC JACKET COLOR:BLUE
2.	CONNECTOR:USB 3.0 A/M, 9P, BLUE INSULATOR SOLDER TYPE, NICKEL PLATED SHELL
3.	CONNECTOR:USB 3.0 MicroB/M, 10P, BLACK INSULATOR SOLDER TYPE, NICKEL PLATED SHELL
4.	PVC MOLDED HOUSING, BLUE COLOR
5.	ABS ASSEMBLY HOUSING, BLUE COLOR
6.	SCREW:#4x33 M2

Jargy part no.	Client part no.	Approved	SCALE	UNIT
CBL-USD302MBS-XmLA			1 : 2	mm
Drawing Name		Drawn	Date	REV.
USB 3.0 A to Micro-B Cable M/M		<i>Kevin Hsu</i>	2016/06/06	1.0

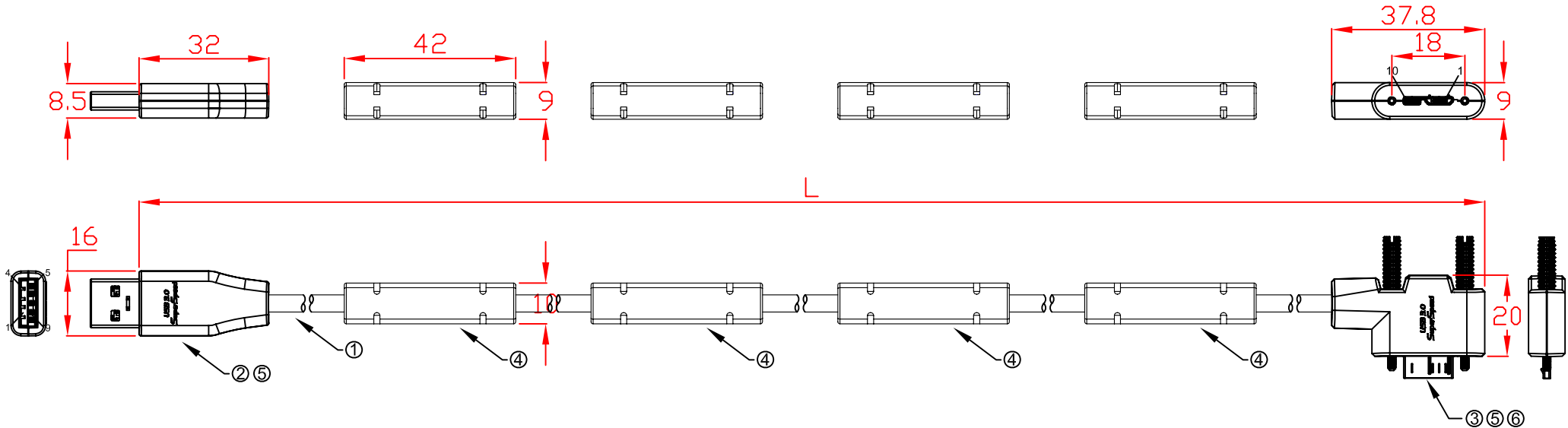

L:

- CBL-USD302MBS-17mRA 17000mm±50mm
- CBL-USD302MBS-18mRA 18000mm±50mm
- CBL-USD302MBS-19mRA 19000mm±50mm
- CBL-USD302MBS-20mRA 20000mm±50mm

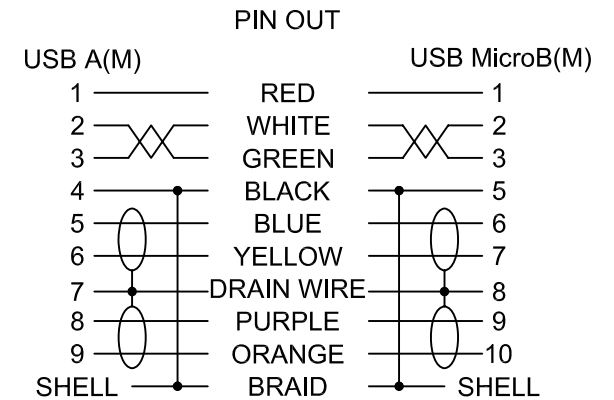

No	MATERIALS LIST:
1.	CABLE:UL2725 (32AWG*1PR+D+AM)x2C+32AWG*1PR+24AWG*1C+AM+B OD:4.2mm PVC JACKET COLOR:BLUE
2.	CONNECTOR:USB 3.0 A/M, 9P, BLUE INSULATOR SOLDER TYPE, NICKEL PLATED SHELL
3.	CONNECTOR:USB 3.0 MicroB/M, 10P, BLACK INSULATOR SOLDER TYPE, NICKEL PLATED SHELL
4.	PVC MOLDED HOUSING, BLUE COLOR
5.	ABS ASSEMBLY HOUSING, BLUE COLOR
6.	SCREW:#4x33 M2

Jargy part no.	Client part no.	Approved	SCALE	UNIT
CBL-USD302MBS-XmRA			1 : 2	mm
Drawing Name		Drawn	Date	REV.
USB 3.0 A to Micro-B Cable M/M		<i>Kevin Hsu</i>	2016/06/06	1.0

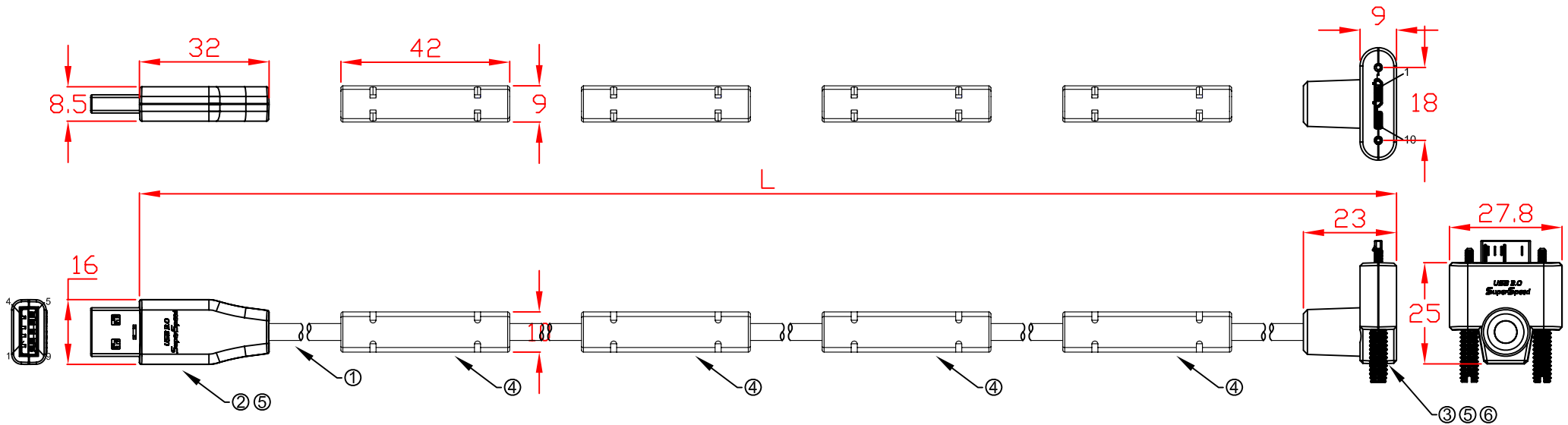

L:

- CBL-USD302MBS-17mUA 17000mm±50mm
- CBL-USD302MBS-18mUA 18000mm±50mm
- CBL-USD302MBS-19mUA 19000mm±50mm
- CBL-USD302MBS-20mUA 20000mm±50mm

USB A(M)

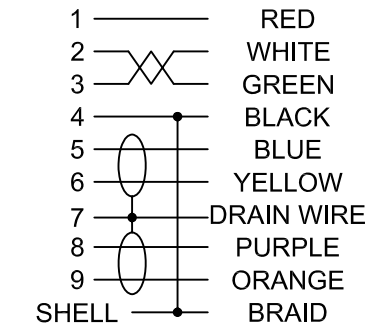

USB MicroB(M)

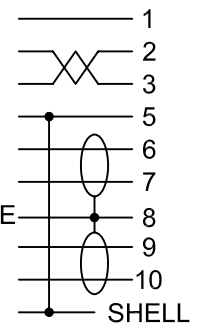

No	MATERIALS LIST:
1.	CABLE:UL2725 (32AWG*1PR+D+AM)x2C+32AWG*1PR+24AWG*1C+AM+B OD:4.2mm PVC JACKET COLOR:BLUE
2.	CONNECTOR:USB 3.0 A/M, 9P, BLUE INSULATOR SOLDER TYPE, NICKEL PLATED SHELL
3.	CONNECTOR:USB 3.0 MicroB/M, 10P, BLACK INSULATOR SOLDER TYPE, NICKEL PLATED SHELL
4.	PVC MOLDED HOUSING, BLUE COLOR
5.	ABS ASSEMBLY HOUSING, BLUE COLOR
6.	SCREW:#4x33 M2

Jargy part no.	Client part no.	Approved	SCALE	UNIT
CBL-USD302MBS-XmUA			1 : 2	mm
Drawing Name		Drawn	Date	REV.
USB 3.0 A to Micro-B Cable M/M		<i>Kevin Hsu</i>	2016/06/06	1.0



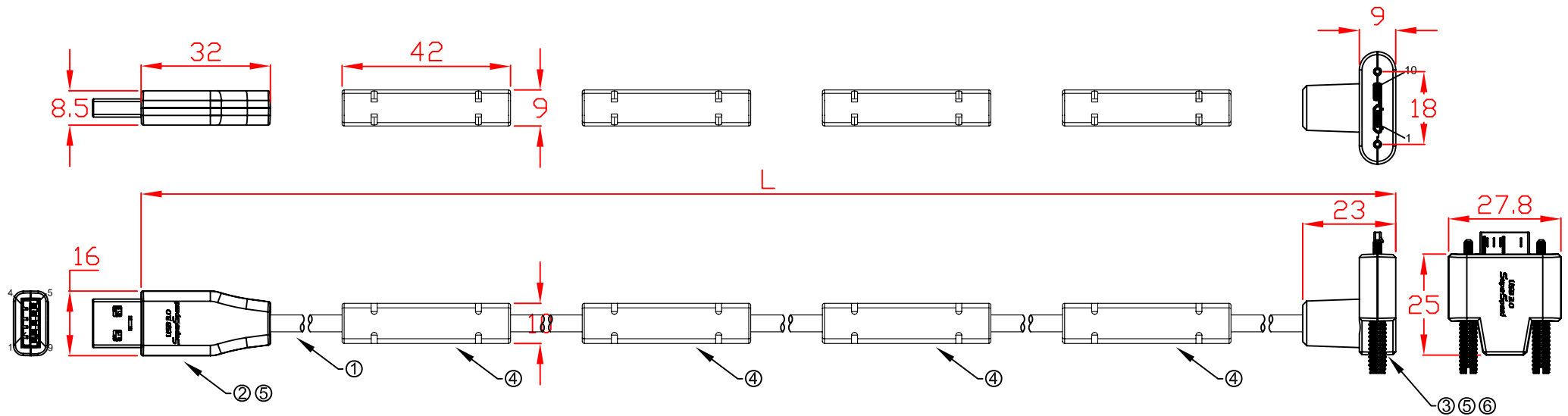

L:

CBL-USD302MBS-17mDA	17000mm±50mm
CBL-USD302MBS-18mDA	18000mm±50mm
CBL-USD302MBS-19mDA	19000mm±50mm
CBL-USD302MBS-20mDA	20000mm±50mm

PIN OUT

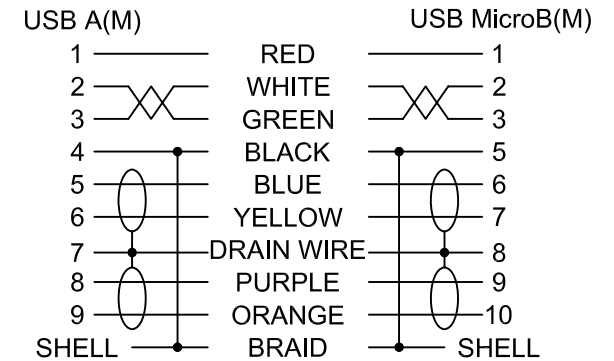

No	MATERIALS LIST:
1.	CABLE:UL2725 (32AWG*1PR+D+AM)x2C+32AWG*1PR+24AWG*1C+AM+B OD:4.2mm PVC JACKET COLOR:BLUE
2.	CONNECTOR:USB 3.0 A/M, 9P, BLUE INSULATOR SOLDER TYPE, NICKEL PLATED SHELL
3.	CONNECTOR:USB 3.0 MicroB/M, 10P, BLACK INSULATOR SOLDER TYPE, NICKEL PLATED SHELL
4.	PVC MOLDED HOUSING, BLUE COLOR
5.	ABS ASSEMBLY HOUSING, BLUE COLOR
6.	SCREW:#4x33 M2

Jargy part no.	Client part no.	Approved	SCALE	UNIT
CBL-USD302MBS-XmDA			1 : 2	mm
Drawing Name		Drawn	Date	REV.
USB 3.0 A to Micro-B Cable M/M		<i>Kevin Hsu</i>	2016/06/06	1.0

